

RomaxWIND

Generating business advantage in the wind energy industry with CATIA and ENOVIA

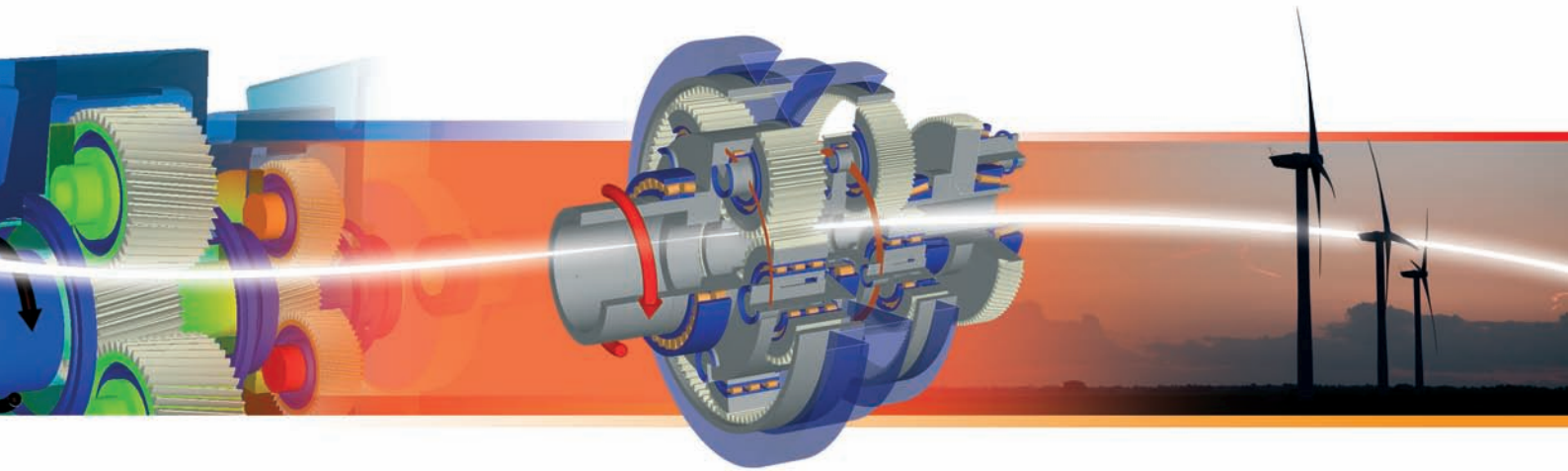

Overview

■ Challenge

In an industry where technology is evolving rapidly, RomaxWIND wanted to increase its competitiveness by optimizing productivity.

■ Solution

The company uses CATIA and ENOVIA SmarTeam to provide detailed design of gearboxes, bearings and drivetrain systems to manufacturers and operators in the wind energy industry.

■ Benefits

CATIA has helped position RomaxWIND at the forefront of wind turbine drivetrain design and development, while ENOVIA SmarTeam provides enhanced product data management and control.



"Deploying Dassault Systèmes PLM provides great manoeuvrability and the confidence that our fully optimized designs can be manufactured to a standard that matches their ingenuity."

David Reetham
Senior Project Engineer
RomaxWIND



International success story

Based in Nottingham, UK, and with facilities across Europe, Asia and the USA, RomaxWIND offers its clients design services, technical consultancy, and simulation technology for the development of wind turbine drivetrain systems.

The globally expanding wind energy industry is pushing technical boundaries. RomaxWIND seeks to meet this challenge by leveraging the knowledge gained in the aerospace, automotive, marine and heavy industries, in which Romax has been operating for 20 years. With more than five years experience in this growing segment, a large portfolio of wind energy projects, and a solid place at the forefront of technical development in renewable energy engineering, RomaxWIND nevertheless wanted to solidify its leadership position by further evolving its unique capabilities and productivity.

Key to the company's success is a strong design capability that produces significantly increased drivetrain efficiencies in wind turbines. David Reetham, Senior Project Engineer at RomaxWIND explained some of the complexity of ensuring maximum efficiency. "Equal load sharing between gears is crucial to ensure reliability and low vibration. By taking into account the effects of structural deflections, mounting conditions, gravity, assembly and manufacturing tolerances, RomaxWIND improves its software simulations to better predict load sharing through each gear."

CATIA for refined designs

Using its own in-house specialized software that defines the gearbox concept and performs macro and micro-geometry analysis, coupled with Dassault Systèmes (DS) CATIA for virtual product design and ENOVIA SmarTeam for collaborative lifecycle management, the company provides the highest quality design and analysis of gearboxes, bearings, and drivetrain systems to manufacturers and operators in the wind energy industry.



“Once we have optimized the drive train specification and features, CATIA is deployed to develop and refine the concept and bring it to a manufacturable state. CATIA is also used to evolve the initial design so that production will synchronize with the 3D digital model as closely as possible.”

ENOVIA SmarTeam for improved productivity

To ensure this complex set of activities proceeds with ease, RomaxWIND uses ENOVIA SmarTeam. The introduction of ENOVIA SmarTeam improves design productivity by offering enhanced configuration and release controls as well as providing sophisticated links between parts and assemblies. Designers log parts and assemblies in and out while version control ensures that order and traceability are always maintained.

“DS PLM technology allows our designers to do more designing and also improves overall data security and quality,” added Reetham. “Dassault Systèmes technology and methodology suit our needs for seamless integration within and beyond our enterprise and across our supply chains. We work on projects internationally

especially in Germany, Denmark, China, India and the USA where major wind power developments are taking place. Dassault Systèmes software is ideal for this type of operation.”

Benefiting from experience

New business opportunities in the wind energy industry are significant and rely on innovative companies adopting technology transfer and marketing strategies that take advantage of the prevailing energy climate.

Using DS PLM in many projects has given RomaxWIND a strong understanding of the methods that deliver optimum results. Subtle alterations to the drive train, blade pitch and yaw, along with highly considered choices of materials and their associated manufacturing techniques have positioned RomaxWIND at the forefront of wind turbine design and development.

David Reetham concluded: “The situation that RomaxWIND has achieved through deploying DS PLM provides great manoeuvrability and the confidence that our fully optimized designs can be manufactured to a standard that matches their ingenuity.”

“Using CATIA and ENOVIA in many projects has given RomaxWIND a strong understanding of the methods that deliver optimum results.”

David Reetham
Senior Project Engineer
RomaxWIND



Dassault Systèmes
10, rue Marcel Dassault
78140 Vélizy Villacoublay – France
+33 (0)1 61 62 61 62

SolidWorks®, CATIA®, DELMIA®, ENOVIA®, SIMULIA® and 3D VIA® are registered trademarks of Dassault Systèmes or its subsidiaries in the US and/or other countries.

Images courtesy of RomaxWIND

© Copyright Dassault Systèmes 2009
All Rights Reserved

For more information or to contact a sales representative, please visit www.3ds.com/contacts

