

# Oguma Industry

Reducing design time for industrial equipment  
by 40% with CATIA PLM Express

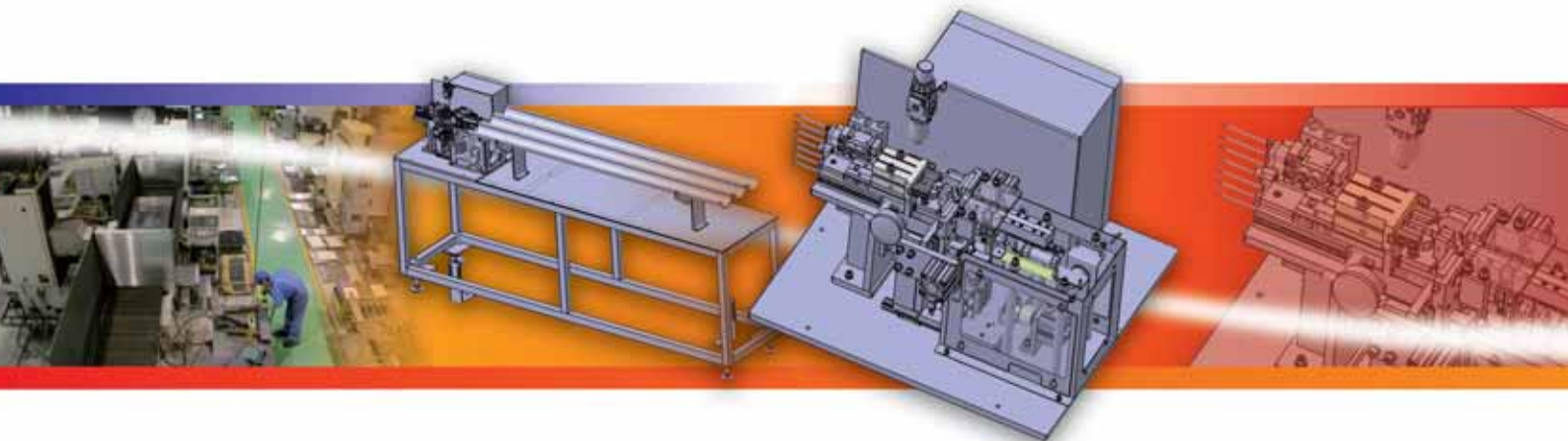

## Overview

### Challenge

*Oguma Industry needed to quickly respond to customer requests and provide them with highly accurate designs.*

### Solution

*The company adopted the CATIA for Industrial Equipment offering based on CATIA PLM Express to reduce new product development time.*

### Benefit

*With CATIA PLM Express knowledge-based design templates, Oguma Industry automates 80% of the design process for its machining jig, reduces design time by 40%, and handles 50% more orders.*



“When I learned that it was possible to introduce CATIA PLM Express at a cost not significantly different from a mid-range 3D design solution, we started to look at CATIA in a different light.”

Katsuyuki Kiriya  
Executive Director, Oguma Industry.



### SMB with a focus on quality

Japan's Oguma Industry designs and manufactures high quality production equipment for automotive components and medical equipment. Founded in 1975, Oguma Industry and its 76 employees specialize in customized products and original designs. “We are very particular about our products, whose designs incorporate our company's state-of-the-art technologies,” said Katsuyuki Kiriya, executive director, Oguma Industry. “Thanks to these technologies, companies our size can differentiate themselves from their competitors.”

### CATIA PLM Express – affordable and scalable solution

In early 2008, after benchmarking various 3D solutions, the company decided to replace its existing 2D design solution with the CATIA for Industrial Equipment offering based on CATIA PLM Express to cut down on the time it habitually spent developing new products.

“While I knew that CATIA had a high degree of functionality, I also thought it was a solution for companies with more than 100 employees. However, when I learned that it was possible to introduce CATIA PLM Express at a cost not significantly different from a mid-range 3D design solution, we started to look at CATIA in a different light,” said Kiriya.

“Our main reason for adopting the solution was its scalability, which will allow us to use it for a long time,” said Katsuyoshi Wakazuki, sub-leader in the Design Engineering Group at Oguma Industry. “Using CATIA PLM Express also makes exchanging data with most of our customers much easier because they are also using CATIA.”

### Template-based jig design

The design team's first 3D project was to design a tool. They leveraged the knowledgeware functions and templates to automate the design of a jig. This jig, or aiming unit, is used on



the production line for automobile lights. "From the moment we decided to adopt a 3D approach with CATIA PLM Express, we rapidly realized the high quality modelling capabilities CATIA offered and started to take advantage of its knowledge functions and templates." said Wakazuki.

### **80% automation and 40% reduction in design time**

For Oguma Industry, the first step toward reducing long bid cycles was to stop designing from scratch. CATIA for Industrial Equipment enabled the company to exploit the knowledge it already has from previous designs and projects. Oguma Industry designers can embed company and international standards into templates, further reducing errors and saving time and money.

With CATIA knowledge-based design templates, Oguma Industry is thus able to automate about 80% of the design process for its machining jig, enabling designers to complete the jig very rapidly. The company has also reduced design time by 40%, achieving quicker order response and enabling it to handle 50% more orders.

In addition, 3D visualization also allows the company to create high quality 3D product images that are much easier to understand than the design drawings previously generated by its former 2D

system. "In a 2D approach, it took time to convert the drawings received from the client to fit the product form and design plan. This was particularly the case for products that had a curved surface, such as the headlights of automobiles, which were difficult to represent using 2D drawings. With 3D the product's shape is immediately recognizable," said Takeshi Iwashita, Design Engineering Group, Oguma Industry.

"Interference checking is also much easier in 3D. Previously, in preliminary reviews with clients, painstaking checks were made to ensure there was no interference, which in 2D was very time consuming," said Wakazuki.

### **Continuous skill improvement**

Oguma Industry is now proceeding with the next phase of its adoption of 3D -- the development of different types of machinery and components for products in other industrial fields. The company will also address small-scale assembly development as well as factory automation design by combining templates and CATIA 2D Layout for 3D Design capabilities. By using 2D Layout for 3D Design, the 2D CAD equipment layout data supplied by the client can be leveraged and an inspection of the jig made possible. And when modifications are made to the 2D data, the 3D model will automatically be updated.



"From the moment we decided to adopt a 3D approach with CATIA PLM Express, we rapidly realized the advantages of using its knowledge functions and templates."

Katsuyoshi Wakazuki  
Group Sub-leader, Design Engineering Group,  
Oguma Industry.



Dassault Systèmes  
10 Rue Marcel Dassault  
78140 Vélizy Villacoublay - France  
+ 33 (0) 1 61 62 61 62

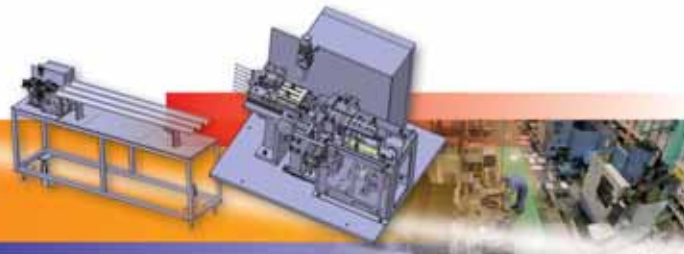

SolidWorks®, CATIA®, DELMIA®, ENOVIA®, SIMULIA® and 3D VIA® are registered trademarks of Dassault Systèmes or its subsidiaries in the US and/or other countries.

Images courtesy of  
Oguma Industry Co., Ltd.

©Copyright Dassault Systèmes 2009.  
All Rights Reserved.

**For more information or to contact  
a sales representative, please visit  
[www.3ds.com/contacts](http://www.3ds.com/contacts)**