

Configuration of a welding tool in 3D.

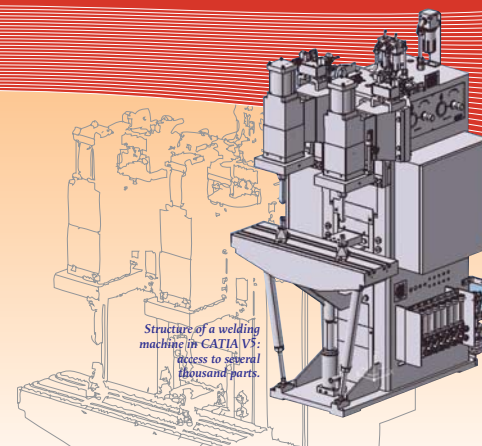

Structure of a welding machine in CATIA V5: access to several thousand parts.



NIMAK series welding machines.

The welding machinery and welding equipment manufacturer NIMAK GmbH can build hundreds of variants of one single type of machine, including special purpose machinery and equipment. CATIA V5 and ENOVIA SmarTeam help to manage the data volumes.

# Managing a Multitude of Variants with ENOVIA SmarTeam

It was a company reorganisation which raised the question as to which CAD system NIMAK GmbH should build on for the future. Two of the company's sites manufacture welding equipment with the product portfolio ranging from hand welding equipment to welding machines and robotic welding guns through to welding lines. Around 200 staff generate an annual turnover of approximately 50 million euros in this area. In 2006, the business divisions were restructured and streamlined, where previously they had not been clearly separated according to site.

most important industries for NIMAK, led to the decision for CATIA V5. In addition, the ENOVIA SmarTeam PDM system was implemented in both plants. At the end of 2006, the implementation started, supported by Dassault Systèmes' partner, DESYS GmbH. "Every user should be able to access the right data at any time without spending a lot of time searching", explained Thomas Roll from the DESYS sales department by way of illustrating an important objective of the project. The result should be the possibility of working with standard data and of using component data easily in a multitude of ways which a design engineer can access when reconfiguring the machines.

The decision to go with CATIA V5 also meant greater consideration of how to manage the product data. Andreas Kipp, project manager and ENOVIA SmarTeam administrator at the NIMAK plant in Nisterberg, notes "We needed ENOVIA SmarTeam for the management of the CATIA data, as the complexity and considerable variation in our products means that the data is quite unmanageable, especially when several design engineers work on one assignment." A whole range of modules already enable extensive automation of standard processes and thus facilitate the work of the design engineers considerably.

## A CAD SYSTEM SPANNING THE PLANTS

With the reorganisation came the decision to implement a standardized CAD system. Experiences with CATIA V4 and the requirements of the automobile industry, one of the

### NIMAK robotic welding arms in action.



Through the work with CATIA V5 in connection with ENOVIA SmarTeam, a standardized procedure is created for all design engineers.

## MULTITUDE OF VARIANTS: A REAL CHALLENGE

In effect, the multitude of variants is a central topic for the welding equipment manufacturer. Thus, equipment and machinery for different welding types are developed which each require different machine types and welding guns. The machines are often built for a specific welding function in series production. The manufacturer operates in all the industries in which metals need to be joined, but particularly in the automobile industry and for nearly all its OEMs and their suppliers. Each welding job is discussed with the customer and the appropriate welding arm, machine or welding line is configured. In series production alone there exists huge variation. So, for example, a machine type can be equipped with four different transformers and can operate with capacitor discharge technology, medium

frequency or alternating current technology. The nosing, i.e. the distance between the machine body and the welding cylinder, can amount to 250, 350 or 550 millimetres. Moreover, there are different types of welding cylinders which can also have different pressures and strokes.

## TEAMWORK IS SUPPORTED

ENOVIA SmarTeam offers the user tangible benefits for teamwork. Once set up in ENOVIA SmarTeam by the PartManager directly from CATIA, every part and component can be located quickly and incorporated into construction. Duplicate work or wrongly stored data are a thing of the past. Change management is intrinsically safer as it is handled automatically via ENOVIA SmarTeam. Errors caused by manual changes do not occur today. Andreas Kipp emphasises: "The benefits of ENOVIA SmarTeam are particularly evident, however, in the configuration and construction of special purpose machines." Components can be reused much more easily from series production or from special solutions that have already been developed. He considers a further positive effect to be teamwork. The current data for a given project is now available to every participant at any time. And "through the work with CATIA V5 in connection with

ENOVIA SmarTeam, a standardized procedure is created for all design engineers. It is no longer each to his own design engineering office."

## POTENTIAL FOR CROSS-DISCIPLINARY DATA FLOWS

The project to introduce CATIA V5 and ENOVIA SmarTeam in NIMAK is not yet over, and the integration of the two systems still requires some effort. Andreas Kipp: "One should not underestimate the adaptation work that is needed." Yet, benefits such as efficient product data management for the many different types of machines and equipment or the consistent work across the team are already visible. Moreover, other potential is coming to the fore: on the basis of the parts list generated by ENOVIA SmarTeam,

the new construction data can be uploaded back into the ERP system in the future as the existing parts list has already been integrated fully in ENOVIA SmarTeam. In addition, plans are afoot to be able to view the planning process and the purchase-related data over a web server and for design engineers to use this for their own work. So, the data worlds of NIMAK GmbH can grow together more and more, not only from one plant to another in terms of construction, but also across disciplines in the whole company. ]

For more information:  
[www.nimak.de](http://www.nimak.de)

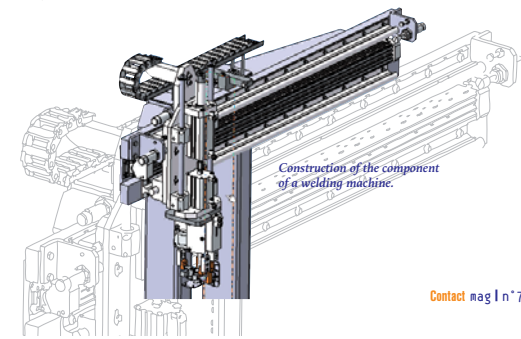

Construction of the component of a welding machine.