

NCSIMUL: the complete solution for NC machine-tool simulation

Spring Technologies has designed the NCSIMUL product structure to bring our customers a top-quality solution delivering all the functionality they need. Verify NC programs, simulate, analyze and compare virtual machined parts before taking them on stream. NCSIMUL is intuitive, easy to use and delivers best-in-class functionalities:

- NC program analysis
- Machining simulation
- Result repurposing

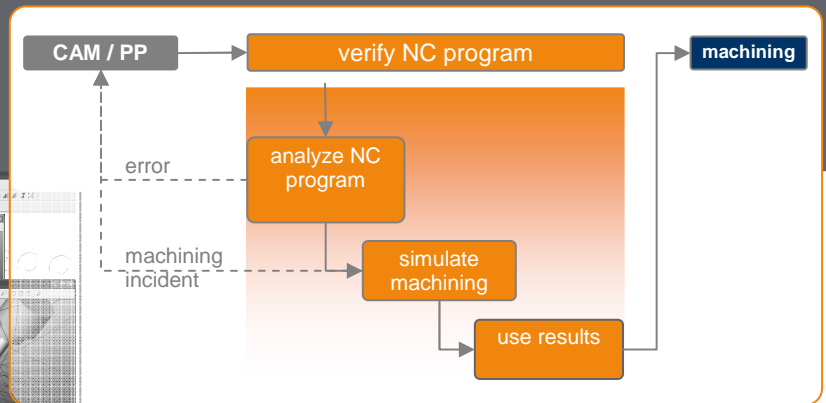
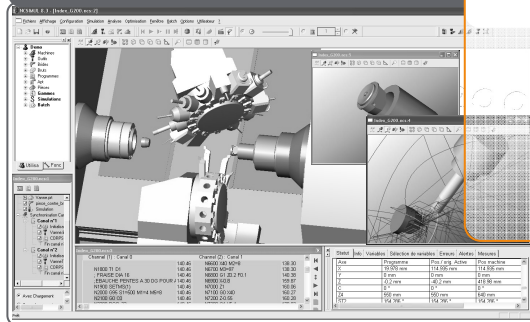

NC program analysis

To enable our customers to minimize the time they spend validating NC programs, NCSIMUL has been designed to analyze the syntax of all NC program types (ISO, conversational), whether post-processed or manual. Designed to comprehensively address the needs of the manufacturing environment, NCSIMUL supports structured programs invoking sub-programs and programs using system variables, loops, and vendor macros, etc.

NCSIMUL eliminates the need to simulate part machining to identify certain programming problems. As soon as the machining job has been loaded NCSIMUL offers:

- Toolpath display

Users can customize the toolpath display (including compensation) enabling a first-level visual analysis to trouble-shoot datum errors and obvious collisions.

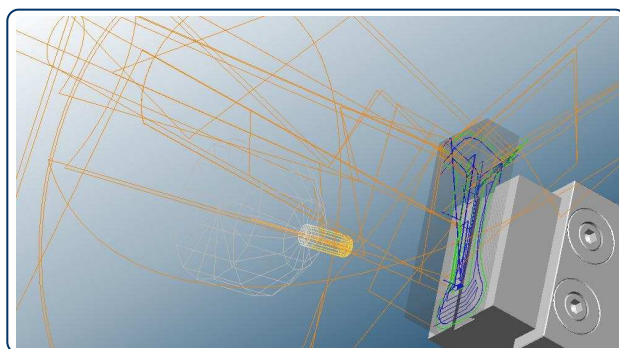

- Error reporting

Before even simulating the actual machining process, NCSIMUL detects and lists a range of errors including:

- Syntax errors
- Out-of-range conditions
- Tool compensation register errors
- Interpolation errors
- Excess speeds

- Dynamically linked windows

All the information, 3D viewing and program windows, etc. are permanently linked. Any changes in the information are dynamically updated. Programmers can consequently analyze NC programs in NCSIMUL with a greater level of interactivity than on a real machine.

- Cycle time per tool sequence

As soon as the program has been loaded, NCSIMUL displays a detailed report showing the different times for each tool and each type of motion (rapid, work, accumulated, etc.) in tabular form. NCSIMUL recognizes the different feeds and speeds and accelerations in each machine axis, enabling an accurate estimation of machining cycle times before the program actually goes into the workshop.

- Interactive program modification with an integrated editor

NCSIMUL's integrated editor lets programmers fix detected errors or try out modifications that are processed immediately by the software.

Machining simulation

– Support for complex kinematics

The result of a 15-year R&D effort, NCSIMUL is capable of simulating any machining center or multi-channel milling lathe, supporting any number of axes, and even unlimited simultaneously operating machines (complete production cells can be simulated).

NCSIMUL comes standard with support for a whole range of all machine environment features including accessories, conveyors, swiveling head, surfacing mills, etc.).

NCSIMUL has also been adopted by leading industry players for its ability to manage machines with parallel kinematics typically occurring on robots, and tricept or hexapod machines.

– Realism

Based on innovative technology, NCSIMUL simulates machine motion at the same time as material removal. Its 3D OpenGL technology facilitates natural 3D manipulation (zoom, rotation, translation) and makes it easy to switch dynamically from window to window without disrupting the simulation process or affecting simulation performance.

The simulation can be interrupted at any time either automatically (each time an alert, tool change, etc. is encountered) or manually to inspect the machined part.

– Reverse simulation

Reverse material removing enables the user to re-build the rough stock volume at a determined point. This option creates a new way of working, step by step, in which the user identifies the problem, corrects it and continues the simulation.

– Probing

NCSIMUL comes standard with probe cycle management for:

- Part probing; datum setting, misalignment compensation, measurement.

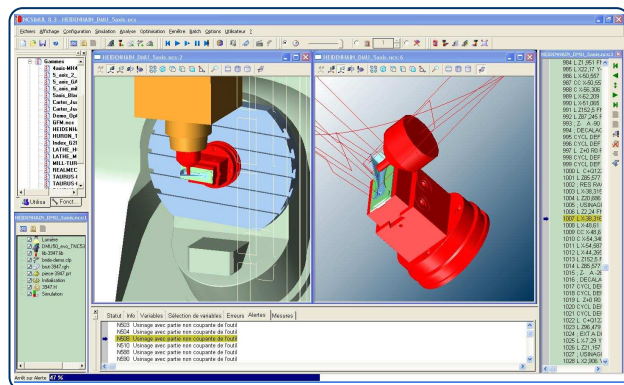

- Tool probing; mechanical or laser.

– Detecting machining incidents

During the simulation, alert detection can be set for all types of collisions and the cutting incidents that typically occur in the workshop (inappropriate tool, spindle stop, rapid motion in the material).

– Tool length optimization

NCSIMUL comes standard with an integrated protruding tool length optimization functionality that can be used to:

- Determine the minimum tool length for each cutting tool, preventing the risk of collisions between the tool holder and the machining environment (rough stock, clamps).
- Minimize the effects of bending on each tool during the different machining operations.

– Save simulation

At any time during simulation, user can stop, save and exit a simulation in progress and easily launch it again.

– Batch mode

All operations of simulation, material removal and collisions can be done in batch mode (automatically).

Repurposing the simulation results

– Measurements

NCSIMUL has a complete range of measurement functions enabling users to check machined parts during and after the machining process. NCSIMUL also recognizes drilling and boring functions to enable the measurement of diameters, center distances or bore holes.

– 3D comparison

NCSIMUL enables standard comparison of machined parts with the theoretical CAD model. Users can themselves set the inspection tolerance to enable instant dynamic viewing of machined zones that fall outside tolerances.

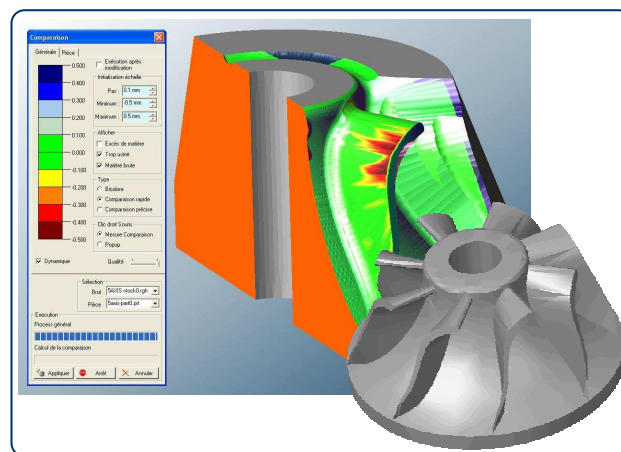

– Dynamic section plans

Users can complete their dimensional analysis by creating dynamic section plans through the machined part.

Colored plan functionalities provide very useful assistance for multi-pocket part.

These plans can be converted into 2D either for further measurement in NCSIMUL or to be directly exported to a CAD software for other purposes (creation of 2D drawings).

for process engineering documentation, measurement in another system, etc.).

– Exporting the results in 3D

The machined part can be exported in 3D at any time to simulate another machining operation in NCSIMUL or for use in a CAM environment.

Simulation report

When NCSIMUL has completed the check, it can generate a simulation report automatically.

This report can list all the elements that form the machining job, notably a detailed list of tools, a 3D view of all the 3D elements such as the machine, the clamps, the rough stocks, etc. This document, in XML format, also contains all the data generated by NCSIMUL such as cycle times, and the list of errors and alerts related to the checked NC programs.

NC converter

NCSIMUL is capable of interpreting any G-code and conversational NC programs (Heidenhain).

- Its ability to rewrite NC programs can be used to convert any NC program to another G-code (or Heidenhain conversational) program for another NC model (identical kinematics).
- This rewrite function can also be used to convert existing NC programs into APT code compatible with the company's CAM technology.

SPRING Technologies' consultants customize the NC converter to adapt it optimally to our customers' machines.

The NC converter is often used by companies who are retrofitting machines and who can no longer post-process the original source CAM programs (APT) because of CAM upgrades, or because they no longer have operating licenses, etc.

The optional CAM interfaces

NCSIMUL is interfaced with the leading CAM vendors. The interfaces available today eliminate the need to duplicate data input and enable:

- The tool library and all the 3D geometrical elements such as rough stocks and clamping systems to be exported to NCSIMUL.
- NCSIMUL to be started up from within the CAM software, with machine loading, and automatic creation of the machining job in NCSIMUL with automatic positioning of the component elements.

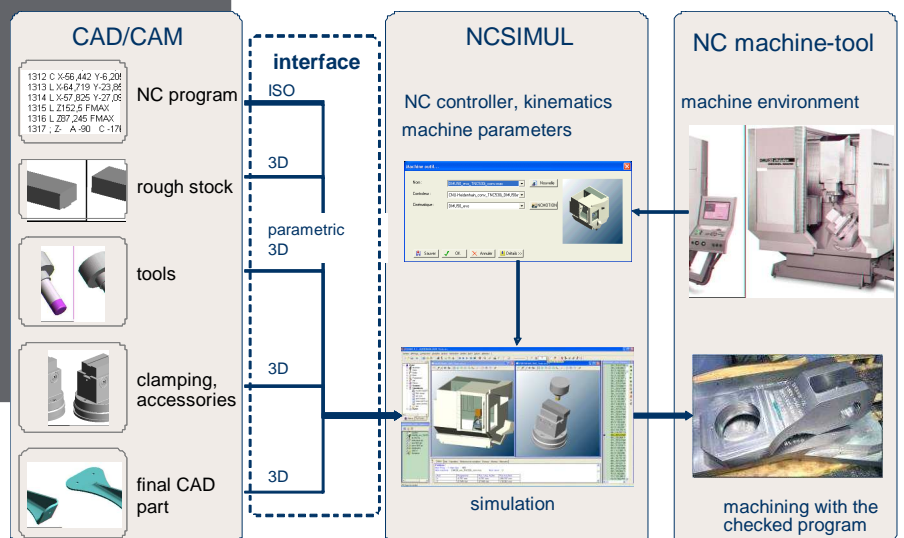

OPTITOOL: the machining optimization module

You can use NCSIMUL's OPTITOOL optimization module to optimize the rapid motion outside the material and the cutting conditions in your NC programs (3 to 5-axis continuous milling operations). This module integrates the following main functionalities:

- Analysis of cutting conditions
- Tool path optimization outside the material
- Optimization of cutting conditions

■ Analysis of cutting conditions

OPTITOOL has a multi-criteria search function that lets users analyze one or more NC programs, for one or more tools based on the company's own cutting criteria. Without modifying the program, OPTITOOL will be able to detect toolpath segments (that can be customized according to tool diameter) that do not match the user's cutting criteria.

■ Optimization of toolpaths outside the material

NCSIMUL users can use OPTITOOL to define their own parameters for tool engage/retract in order to minimize motion at cutting speed outside the material, replacing this motion with fast feed.

■ Learning Mode

Based on the maximum feed rate and maximum chip flow per teeth and material volume limit, OPTITOOL capitalizes on existing program limits and delivers best cutting conditions.

Optimization of cutting conditions

Based on the innovative Tool Material Combination technology developed by SPRING Technologies, OPTITOOL supports the leading combinations used in industry for the last twenty years, by defining distinct zones along the tool path.

NCSIMUL users are free to choose to optimize cutting conditions (feeds and rotation speeds) to match specific materials (A_p , A_e) and the predefined tool strategy (to optimize tool lifetime, maximum feed rate, surface roughness, etc.).

OPTITOOL also lets users develop and maintain their own tool-material combinations, based on their experience in the workshop, and embodying the company's know-how.

