

Grundfos

Revolutionising pump technology with PLM solutions from IBM and Dassault Systèmes



Grundfos Objectives

- Constantly innovate product design to meet strict efficiency targets
- Expand design and production capabilities to match company globalisation
- Increase automation for the development of complete pumping solutions

Company Overview

Founded in Bjerringbro, Denmark in 1945 as a family-run die and machine factory, Grundfos has grown into one of the world's leading pump manufacturers. A privately owned company, Grundfos employs more than 17,000 people in 42 countries and posted 2006 earnings of €2.06 billion.

Deeply committed to sustainable development and social responsibility, Grundfos adheres closely to its core values of: BE responsible, THINK ahead & INNOVATE. In addition to groundbreaking pumps and pump systems, Grundfos also develops electric motors and high-technology electronic equipment that make pumps "intelligent" and increase their efficiency.

Business Challenges

"Contributing to a better quality of life and a healthy environment" is part of the Grundfos corporate mission. In keeping with this goal, the company has established a demanding product quality objective – each year, 80% of all updated pump models must be at least 5% more efficient than the previous version – a challenging target that requires constant design innovation.

Faced with a shortage of skilled labor in Denmark, Grundfos continues to globalise its operations to ensure the availability of engineers, as well as to be close to its customers in fast growing, emerging markets. Coordinating design and production activities across the globe while maintaining high quality standards presents a unique set of collaboration challenges.

Finally, Grundfos is moving toward developing complete pumping solutions versus special-purpose machines. These complete pumping solutions require increased use of standardised parts, automation, and robotics, yet must still be customisable for specific customer needs.

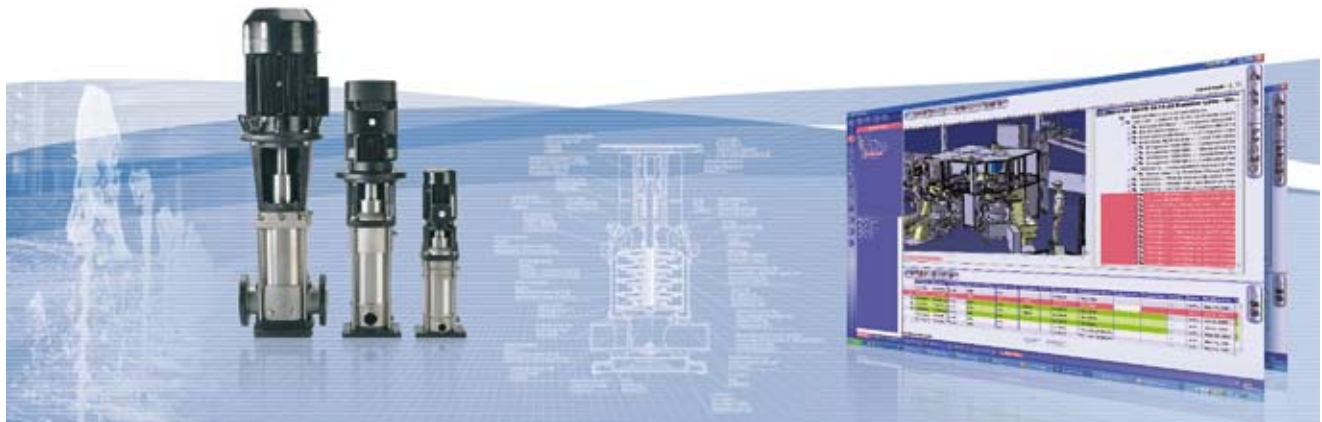

Solution

An early adopter of IBM and Dassault Systèmes PLM solutions, Grundfos began using CATIA V2 in 1987 to accelerate and improve the mechanical design of its pumps. Today, Grundfos has 450 CATIA V5 and ENOVIA VPLM users in 15 sites around the world. “Globalisation of the company is a top priority at Grundfos and that creates a strong demand for tools,” said Lars Peder Hansen, Senior Systems Consultant, Grundfos.

The majority of Grundfos PLM users work in the company’s Business Development Centre (BDC), the R&D division dedicated to creating and marketing new pump products. The BDC is highly distributed with users in Denmark, China, the USA, and Hungary. It also includes Grundfos’ Nonox unit which develops innovative dosing pumps for the automotive sector. The Grundfos Technology Centre, the division that develops the tooling and production equipment used to manufacture BDC products, also uses PLM.

“The BDC is our client,” said Jacob Dirks, Technology Director, Grundfos Technology Centre. “To deliver our new production lines on time, we have to ‘automate automation’ by reusing existing practices and designs. PLM solutions are vital for this since they allow us to create, store, and leverage our know-how.”

CATIA for advanced 3D design

Grundfos engineers use CATIA to design the company’s entire line of pumps and pump products, production equipment, and testbeds. CATIA enables them to design directly in the context of the 3D digital mock-up, quickly define virtual prototypes, and simulate and analyse the behavior of the complete pumps in action within the design environment with FEM Surface and Solid analysis tools.

Grundfos uses CATIA in combination with other simulation software to optimise the efficiency of its products in order to lower the energy consumption of the pumps.

CATIA is instrumental in helping Grundfos to reuse previous product design and develop standard parts. Design rules, pre-approved standard components, pre-defined norms, and know-how are captured and embedded in the design definition to be easily applied to new projects. These intelligent, built-in knowledge templates automatically select and adapt the appropriate standards to new customer requirements. The design phase can be dramatically optimised because engineers are able to get a



*Jacob Dirks
Technology Director
Grundfos Technology Centre*

“PLM solutions from IBM and Dassault Systèmes help Grundfos design more innovative products. This helps us to meet our corporate goal of increasing pump efficiency by 5% each time we update a model.”



Lars Peder Hansen
Senior Systems Consultant
Grundfos

“IBM-DS PLM solutions foster innovation. They give engineers powerful tools to express their ideas and free them from tedious, repetitive tasks so they can focus on creation.”

quick and relevant design by reusing previous product designs, allowing them to spend more time on innovation and focus on precise customers' needs.

In addition, CATIA generates 2D drawings for maintenance and production documentation that are then loaded into the company's ERP system.

ENOVIA VPLM for global collaborative engineering

By providing a single, easy-to-access repository of all in-work design data, ENOVIA VPLM enables Grundfos' geographically dispersed engineering teams in the BDC, Technology Centre, and regional R&D sites to develop products concurrently.

“Designers from the Technology Centre access CATIA designs created by the BDC and stored in ENOVIA VPLM early in the design process,” said Winnie Stenkjaer, Department Head, Grundfos Technology Centre. “This allows us to determine manufacturing feasibility right from the start.”

ENOVIA VPLM also offers Grundfos engineers advanced relational design by managing the dynamic knowledge and associations that foster engineering innovation. When the engineer's design iterations are finalised, ENOVIA automatically propagates the changes across hundreds of parts and communicates them to the relevant teams.

Results

The use of IBM and Dassault Systèmes PLM solutions at Grundfos has led to considerable time gains in the development cycle, more efficient design processes, and enhanced product quality and innovation.

Concurrent engineering for shorter development time

Concurrent engineering processes in PLM have enabled the Grundfos Technology Centre to rapidly develop innovative solutions for the increasingly sophisticated bids from the BDC. One recent success involved the delivery of a new design for an entire industrial pump assembly line. “To meet the challenging three-month deadline for mechanical engineering,” said Winnie Stenkjaer, “we had to engage eight designers working in parallel for the first time. VPLM allowed us to match the new pump components with the new parts in the production machines far more efficiently.”

Concurrent engineering also benefits Grundfos' new business divisions such as the specialised BioBooster unit that develops bacteria-driven, industrial wastewater treatment solutions for facilities such as slaughterhouses and dairies. "Designing in parallel with my colleagues halves the time I need to create an assembly," said Anders Dalsgaard, Design Engineer Grundfos BioBooster.

Leveraging design capital

Using ENOVIA VPLM, Grundfos can better support its globalisation agenda by providing all engineers with a shared database of reusable parts and practices, in both production line machinery and in pump design. This enables designers on a companywide basis to quickly build new customised combinations out of proven specifications.

"Seventy percent of the design for a new production line test bed is created from existing knowledge," said Stenkjaer. "By reusing design knowledge captured in intelligent templates in CATIA and made available through ENOVIA, we have increased the efficiency of our design process for tools and test beds by 20%."

More flexible design practices

The combined capabilities of CATIA Knowledge-based Modelling, Design in Context, and FEM analysis have allowed Grundfos engineers to explore more innovative possibilities to squeeze even 1% more efficiency from a pump, while grounding the results in the bigger picture.

"Design in Context is vital for determining constraints," said Anders Dalsgaard. "When I design a new part, I immediately place it in an assembly to see how it fits. Using CATIA, it took me only three months to build a container for a new pump instead of a year."

PLM key benefits:

- 50%

Development time

using concurrent engineering

+ 20%

Design efficiency

with part design reuse in CATIA

**Ten-fold increase in
analysis productivity**

with part design reuse in CATIA

**Enhanced innovation
and product quality**

via comprehensive PLM design modules

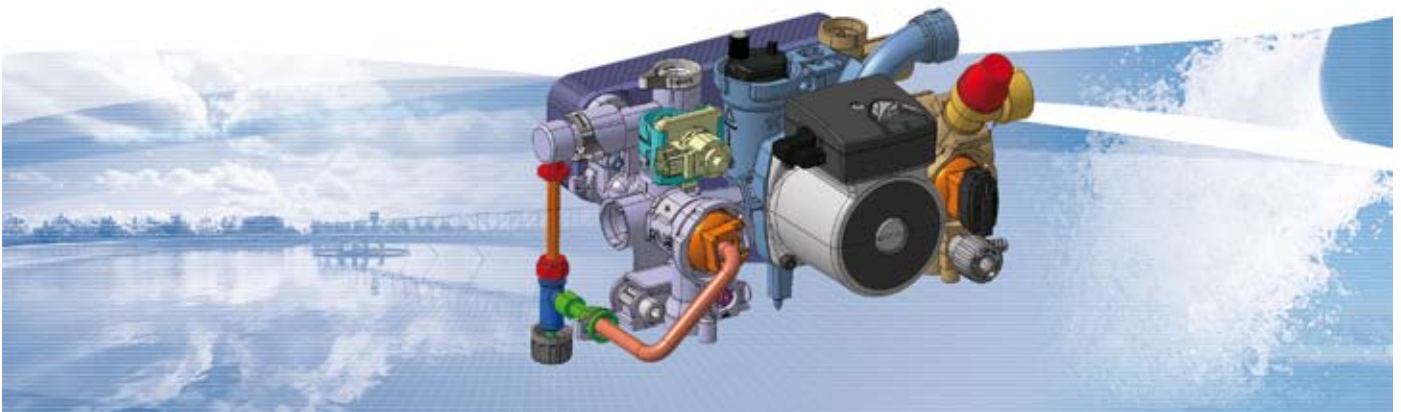



Winnie Stenkjaer
Department Head
Grundfos Technology Centre

“By reusing design knowledge captured in intelligent templates in CATIA and made available through ENOVIA, we have increased the efficiency of our design process for tools and test beds by 20%.”

Grundfos pumps must meet a variety of local safety requirements. The CATIA FEM module is used to make sure that the mould required to create composite parts is designed in full compliance with the standards for withstanding the pressure inside the pump. “Without FEM,” said Anders Dalsgaard, “it would take ten times longer and cost ten times as much. With CATIA, the mold now works right the first time.”

CATIA also makes it easy to make modifications late in the design process by simply changing design parameters, thereby allowing dramatic cost and time savings. “Now that all product specifications are held in the PLM database, “it’s far easier to modify designs,” said Ole Høg, Senior Systems Consultant, Grundfos. “We sometimes need to modify parts in an iterative process right up to the last minute. CATIA helps us do this far more easily.”

Enhanced innovation

The innovation process at Grundfos inevitably involves working to the specific constraints of pumping systems while attempting to extract the maximum benefits from new concepts. This demands clear communication among all actors ranging from engineers to biologists.

“My challenge is to control biology with mechanics,” said Dalsgaard. “CATIA helps me to create designs that a biologist can visualise and understand. It includes features such as the section view that help me illustrate my ideas.”

“IBM-DS PLM solutions foster innovation. They give engineers powerful tools to express their ideas and free them from tedious, repetitive tasks so they can focus on creation,” said Lars Peder Hansen.



A non-disruptive implementation

Implementation of CATIA and ENOVIA VPLM went smoothly at Grundfos. Deployment was completed ahead of schedule thanks to training and project management provided by IBM personnel familiar with the Grundfos business and technical environment.

“IBM supported the implementation with key resources throughout all phases and was a contributor to the project’s success,” said Hansen.

Additional benefits achieved with IBM-DS PLM*	
Benefit area	Reduced by
Production error costs	80%
New parts created	10%
Assembly line layout design time and costs	30%
Manufacturing cycle time (days)	20%
Penalties for late delivery to customers	65%

*Findings based on Return on Investment study performed by CIMdata



Anders Dalsgaard
Design Engineer
Grundfos BioBooster

“My challenge is to control biology with mechanics. CATIA helps me to create designs that a biologist can understand.”

Future

To harness the design power of its now widely distributed R&D base, Grundfos plans to implement a critical “Distance Project” as part of its VPLM strategy. This project will make one master ENOVIA database available, together with three smaller local databases in Denmark, US, and China, and involve replication between them. IBM’s DB2 database technology will support the project with high performance replication of the VPLM data. This ambitious project is intended to deliver concurrent engineering capability at a truly global level.



IBM and the IBM logo are registered trademarks of International Business Machines in the United States, other countries or both.

For more information, visit

www.ibm.com/solutions/plm

CATIA, ENOVIA and 3DS logo are registered trademarks of Dassault Systèmes or its subsidiaries in the US and/or other countries.

For more information, visit

www.3ds.com

